

Shield MD-V2

Motion Detector

Schütz
Premium Qualität

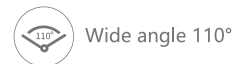
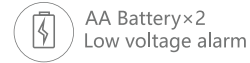

Technical Parameter

• Input Power	DC12V 1A external cable DC5V 2A Type-C USB
• Built-in Battery	3.7V5000mAh lithium battery
• Working Power Consumption	<5W
• Working Temperature	-10°C~+50°C
• Relative Humidity	<95% (no condensation)
• Wireless Parameters	433MHz
• Wired Defense Zone	8
• WiFi Standard	IEEE802.11b/g/n 2.4G band
• Product Size	183x 135x 18mm

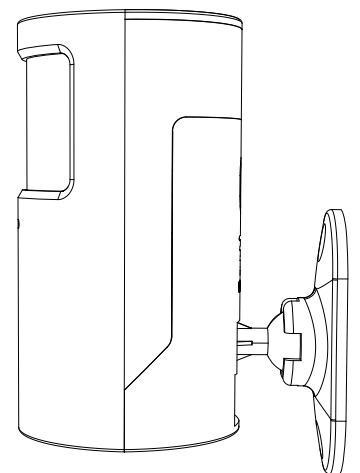
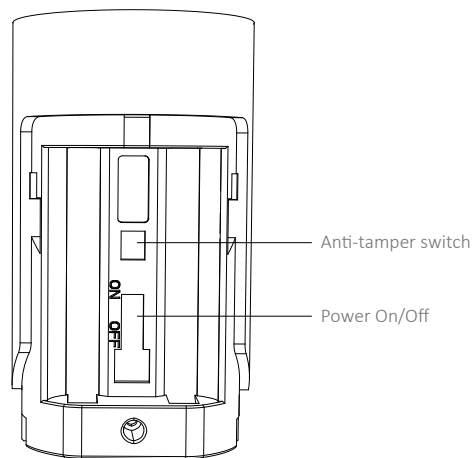
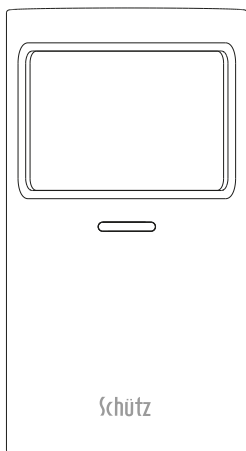

Schütz

Excellence through Innovation

1 Year Worry-free Warranty



App Store



Google Play



Web Link